

GRADE 7
Mathematics

Modified

Administered April 2014

RELEASED

STAAR GRADE 7 MATHEMATICS REFERENCE MATERIALS

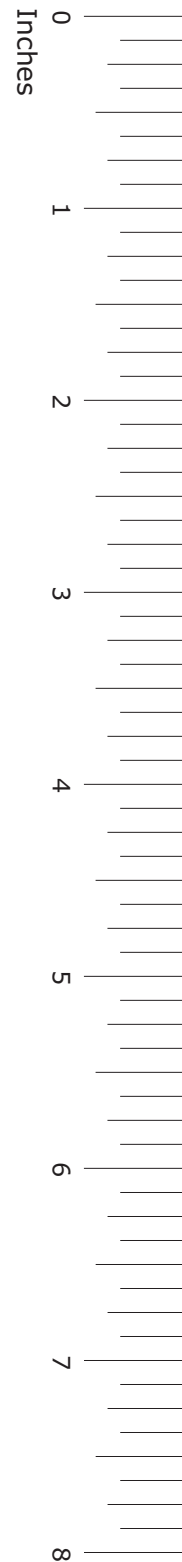
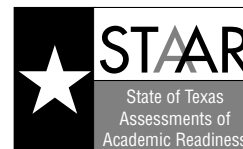

LENGTH

Customary

1 mile (mi) = 1,760 yards (yd)

1 yard (yd) = 3 feet (ft)

1 foot (ft) = 12 inches (in.)

Metric

1 kilometer (km) = 1,000 meters (m)

1 meter (m) = 100 centimeters (cm)

1 centimeter (cm) = 10 millimeters (mm)

VOLUME AND CAPACITY

Customary

1 gallon (gal) = 4 quarts (qt)

1 quart (qt) = 2 pints (pt)

1 pint (pt) = 2 cups (c)

1 cup (c) = 8 fluid ounces (fl oz)

Metric

1 liter (L) = 1,000 milliliters (mL)

WEIGHT AND MASS

Customary

1 ton (T) = 2,000 pounds (lb)

1 pound (lb) = 16 ounces (oz)

Metric

1 kilogram (kg) = 1,000 grams (g)

1 gram (g) = 1,000 milligrams (mg)

TIME

1 year = 12 months

1 year = 52 weeks

1 week = 7 days

1 day = 24 hours

1 hour = 60 minutes

1 minute = 60 seconds

STAAR GRADE 7 MATHEMATICS REFERENCE MATERIALS

PERIMETER

Rectangle

$$P = 2l + 2w$$

CIRCUMFERENCE

Circle

$$C = 2\pi r$$

or

$$C = \pi d$$

AREA

Triangle

$$A = \frac{1}{2}bh$$

Rectangle

$$A = bh$$

Parallelogram

$$A = bh$$

Trapezoid

$$A = \frac{1}{2}(b_1 + b_2)h$$

Circle

$$A = \pi r^2$$

VOLUME

Triangular prism

$$V = Bh$$

Rectangular prism

$$V = Bh$$

Cylinder

$$V = \pi r^2 h$$

or

$$V = Bh$$

ADDITIONAL INFORMATION

Pi

$$\pi \approx 3.14$$

or

$$\pi \approx \frac{22}{7}$$

20

19

18

17

16

15

14

13

12

11

10

9

8

7

6

5

4

3

2

1

0

Centimeters

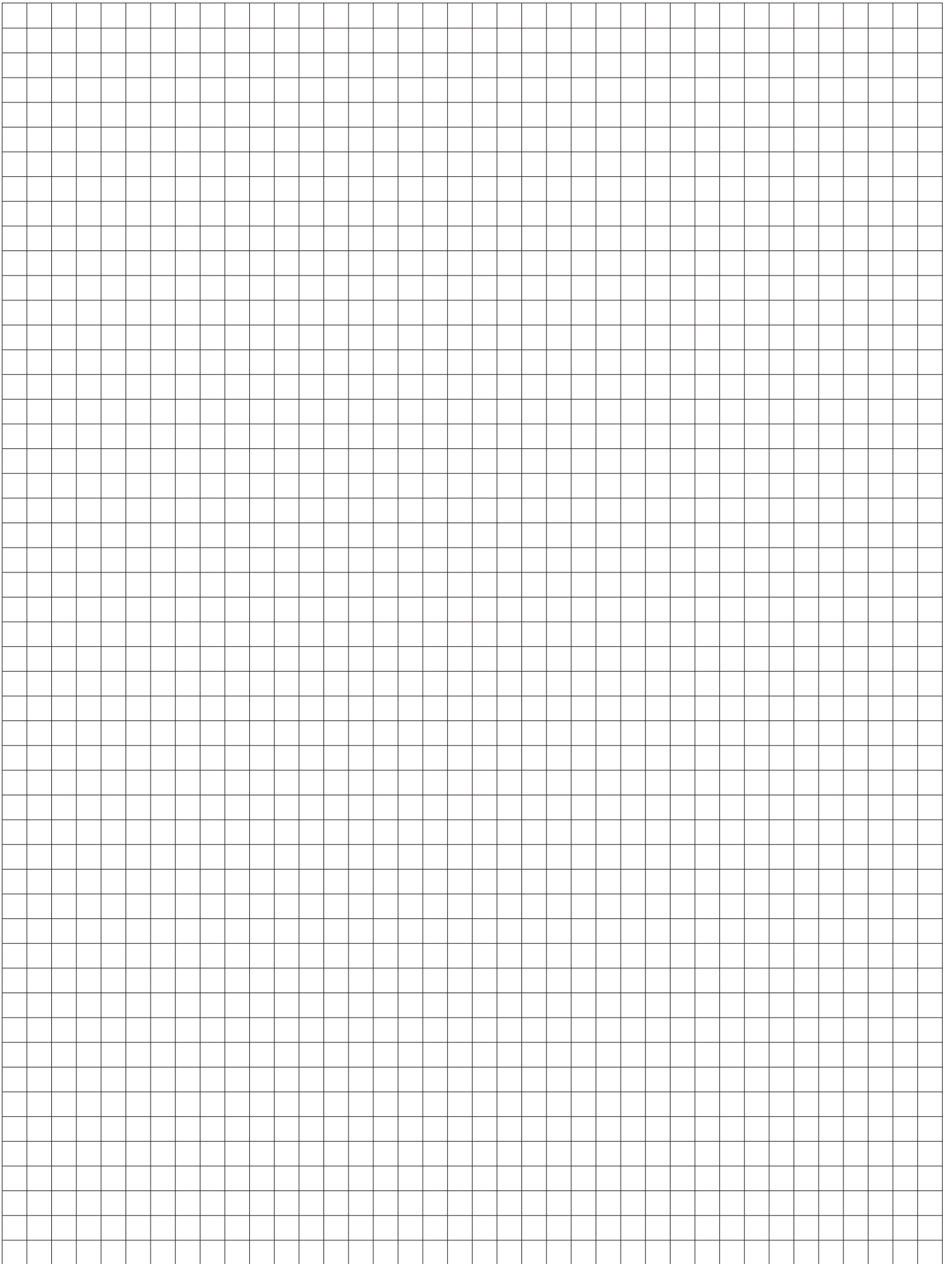

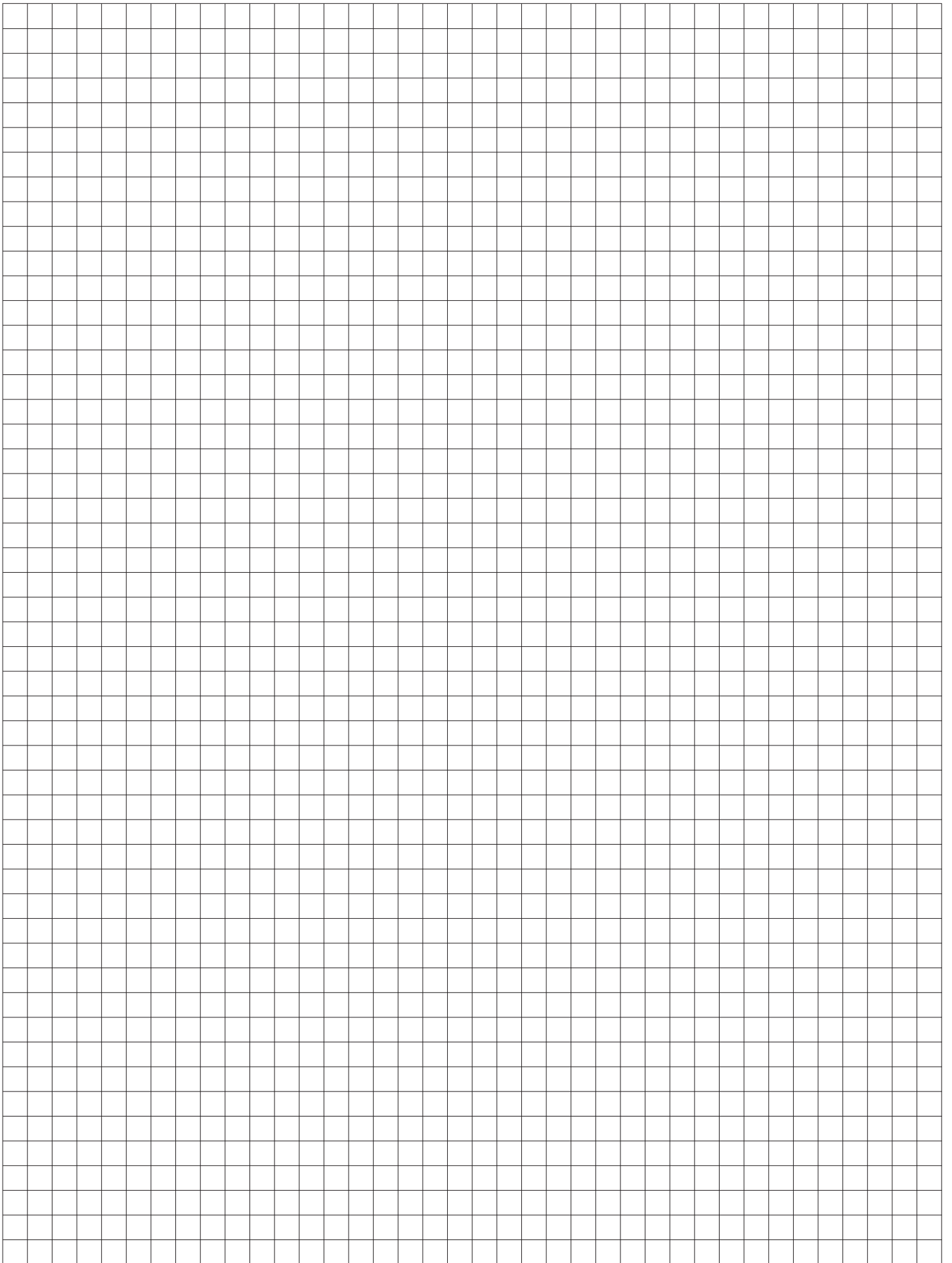

MATHEMATICS

DIRECTIONS

Read each question. For a multiple-choice question, choose the best answer from the three choices provided and fill it in on your answer document. For a griddable question, fill in your answer in the grid on the answer document.

- 1 Look at the triangle below. The side lengths are given in centimeters (cm).

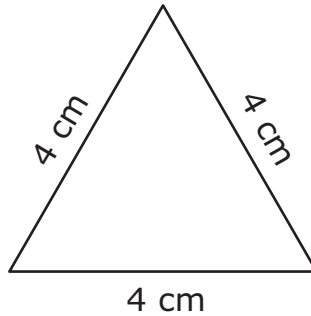

Which of these describes the triangle?

- A Scalene
- B Right
- C Equilateral

2 In a random survey 18 of 40 people knew which team won the Super Bowl last year. What percent of the people surveyed knew which team won?

F 22%

G 45%

H 58%

3 The list below shows the age of each person in Chin's family.

5, 11, 11, 13, 42, 44

What is the median age in Chin's family?

A 12

B 21

C 24

- 4 Antonio measured the lengths of three items on a desk. The table below shows the length of each item in inches.

Item Lengths

| Item | Length (inches) |
|------------|-----------------|
| Eraser | 0.75 |
| Staple | $\frac{1}{4}$ |
| Paper clip | $\frac{7}{8}$ |

According to the table, which item has the greatest length?

- F Eraser
- G Staple
- H Paper clip

5 Lorena is reading a map. The scale on the map shows that 1 inch represents 100 miles. What is the number of miles represented by $3\frac{1}{4}$ inches on this map?

- A** 400 miles
- B** 33 miles
- C** 325 miles

6 A list contains 3 numbers.

- The first number is twice the second number.
- The second number is $\frac{1}{3}$ of the third number.
- The third number is 2 more than the first number.

Which of these could be the list of 3 numbers?

- F** 5, 10, 7
- G** 4, 2, 6
- H** 6, 3, 9

7 Look at line segment UV on the grid below.

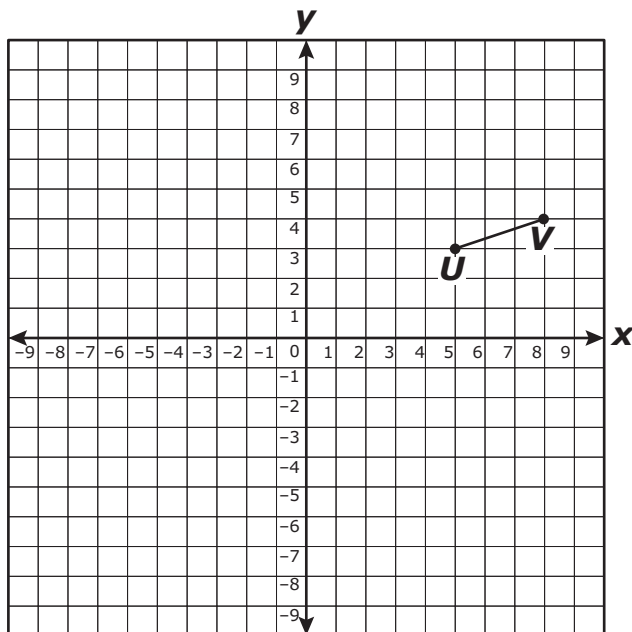

If line segment UV is reflected across the y -axis, which ordered pair represents the reflection of point U ?

- A $(-5, 3)$
- B $(-4, 8)$
- C $(3, -5)$

- 8** Manuel recorded the time he spent doing three activities. The results are shown in the table below.

Manuel's Time

| Activity | Time (minutes) |
|----------------------|----------------|
| Talking on the phone | 25 |
| Doing his homework | 90 |
| Playing outside | 45 |
| Total | 160 |

Which statement is supported by the data in the table?

- F** Manuel spent exactly 20% of his time talking on the phone.
- G** Manuel spent twice as much time doing his homework as playing outside.
- H** Manuel spent exactly 30% of his time playing outside.

9 The front and right-side views of a three-dimensional figure are shown below.

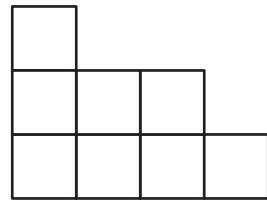

Front view

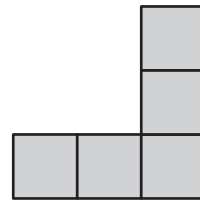

Right-side view

Which figure can be represented by the views above?

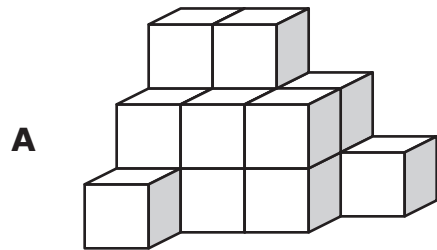

Front

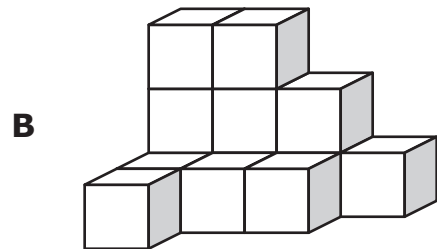

Front

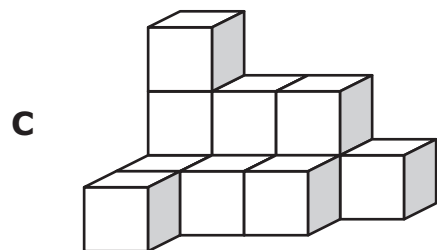

Front

10 Samantha drove 165 miles in 3 hours without making any stops. What was her average driving speed in miles per hour?

You may practice recording your answer in the grid below.

| | | | |
|---|---|---|---|
| | | | . |
| 0 | 0 | 0 | |
| 1 | 1 | 1 | |
| 2 | 2 | 2 | |
| 3 | 3 | 3 | |
| 4 | 4 | 4 | |
| 5 | 5 | 5 | |
| 6 | 6 | 6 | |
| 7 | 7 | 7 | |
| 8 | 8 | 8 | |
| 9 | 9 | 9 | |

Record your answer and fill in the bubbles on your answer document. Be sure to use the correct place value.

11 The dimensions of a floor in feet (ft) are shown below.

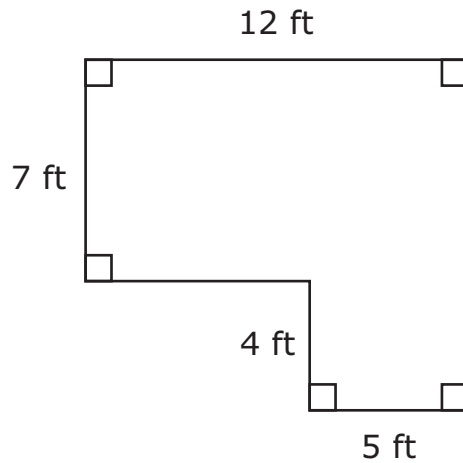

$$A = bh$$

Area of a rectangle = base \cdot height

What is the area of this floor?

- A** 46 square feet
- B** 104 square feet
- C** 132 square feet

12 Which relationship is best represented by the graph below?

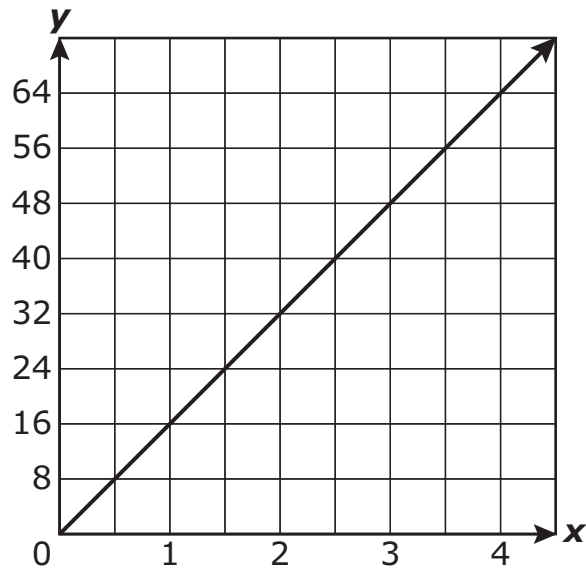

- F** The number of hours in a day
- G** The number of cups in a gallon
- H** The number of inches in a foot

13 Juanita bought concert tickets.

- She bought 8 tickets.
- The tickets cost between \$25 and \$45 each.

Which of these could be the total cost of these tickets?

A \$280

B \$400

C \$160

14 Alan bought two books.

- The cost of the first book can be represented by f .
- The cost of the second book was \$11.
- The total cost of the books was \$20.

Which equation represents this situation?

F $f \cdot 11 = 20$

G $f + 20 = 11$

H $f + 11 = 20$

15 Look at the Venn diagram below. It shows how Set M and Set N are related.

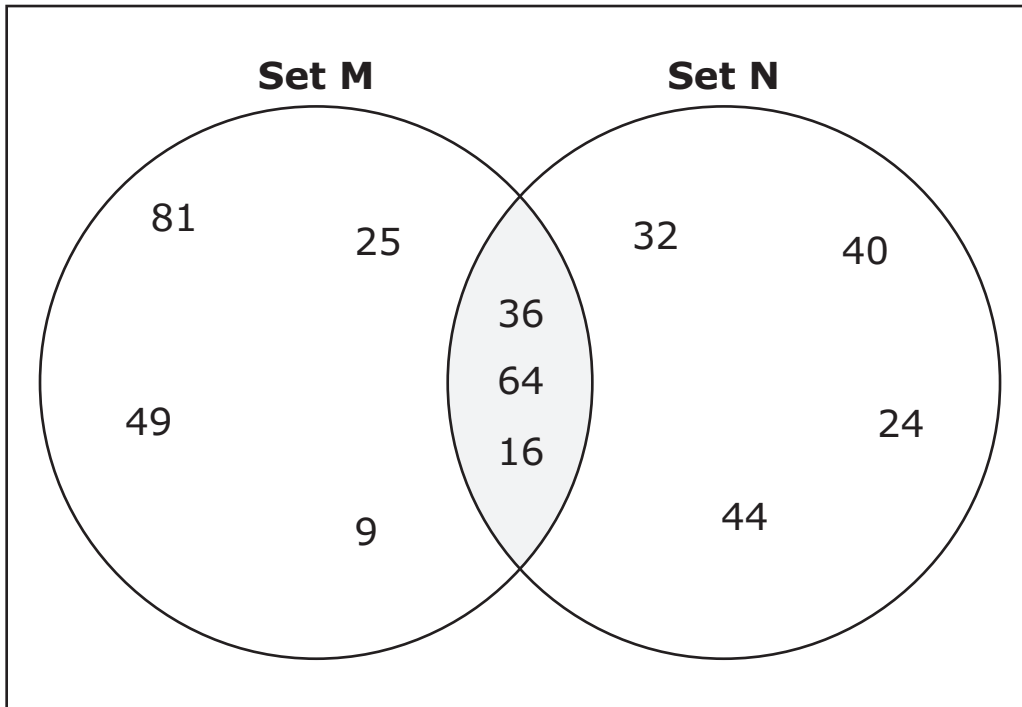

Which statement describes the numbers that are in both Set M and Set N?

- A** They are all multiples of 8.
- B** They are all perfect squares and multiples of 4.
- C** They are all multiples of 6.

16 A party store rents and sells supplies.

- The store rents helium tanks to fill balloons for \$60.
- The store sells 4 balloons for \$1.

A customer paid \$70 to rent a tank and buy balloons. How many balloons did the customer buy?

F 240

G 520

H 40

17 Angle K and angle M are supplementary angles. The measure of angle K is 132° . What is the measure of angle M ?

A 48°

B 42°

C 58°

- 18** Look at the container below. It is in the shape of a rectangular prism. The container is filled with water to a height of 22 inches (in.).

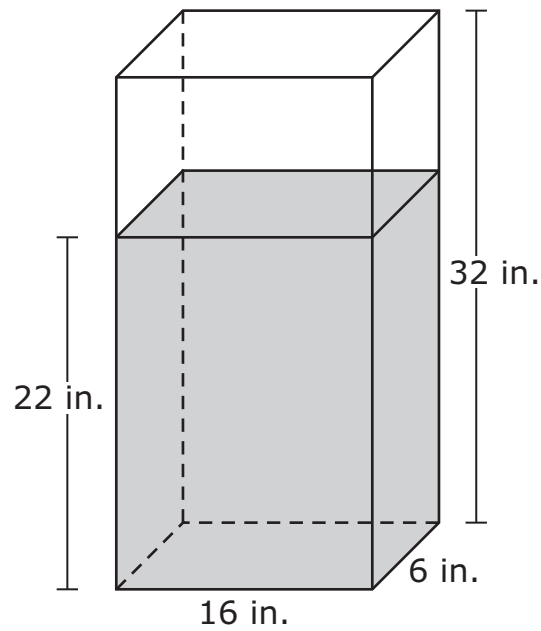

$$V = Bh$$

Volume of a rectangular prism = length · width · height

What is the volume of the water in this container?

- F** 960 cubic inches
- G** 484 cubic inches
- H** 2,112 cubic inches

19 Quadrilateral $KLMN$ is similar to quadrilateral $PQRS$.

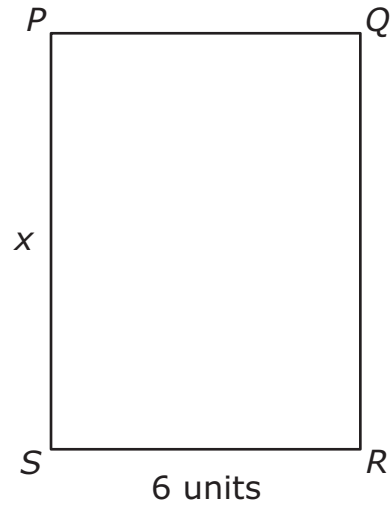
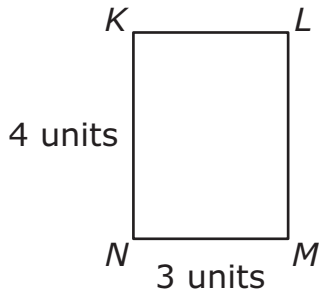

Which proportion can be used to find the value of x in units?

A $\frac{4}{3} = \frac{6}{x}$

B $\frac{3}{7} = \frac{6}{x}$

C $\frac{3}{4} = \frac{6}{x}$

- 20** A carpenter recorded the weights of 9 tools in a workshop. The results are shown in the line plot below.

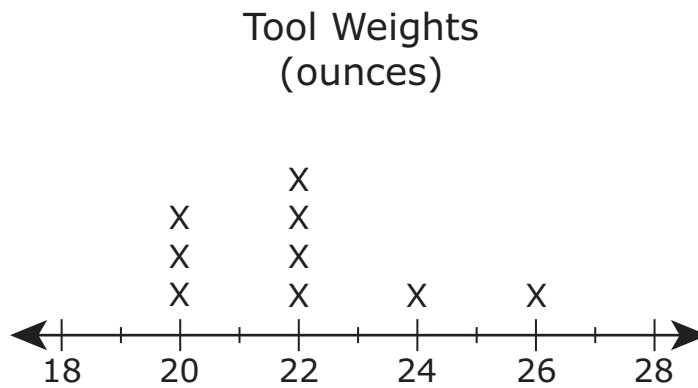

Which measure of data should the carpenter use to determine the most common weight of these 9 tools?

- F** Mode
- G** Range
- H** Mean

21 Look at the table below. It shows a sequence where n represents the position of a term.

| | | | | | |
|--|---|---|---|----|-----|
| | 1 | 2 | 3 | 4 | n |
| | 3 | 6 | 9 | 12 | ? |

Which expression can be used to find the value of the n th term?

A $n + 3$

B $3n$

C $n + 4$

22 Ryan, Samir, and Teresa collected cans of food for a food drive.

- Ryan collected 30 cans.
- Samir collected 3 times as many cans as Ryan did.
- Teresa collected 6 more cans than Samir did.

How many cans did Teresa collect?

F 84, because $30 \cdot 3 = 90$ and $90 - 6 = 84$

G 16, because $30 \div 3 = 10$ and $10 + 6 = 16$

H 96, because $30 \cdot 3 = 90$ and $90 + 6 = 96$

23 Which situation is represented by the equation $7t + 3 = 31$?

- A** Alex spent \$31 at a movie theater. He bought 7 tickets. How much did each ticket, t , cost?
- B** Alex spent \$31 at a movie theater. He bought one ticket and spent \$3 each to buy 7 drinks. How much did the ticket, t , cost?
- C** Alex spent \$31 at a movie theater. He bought t tickets for \$7 each and one drink for \$3. How many tickets did Alex buy?

24 A circular mirror is shown below. It has a radius of 21 inches (in.).

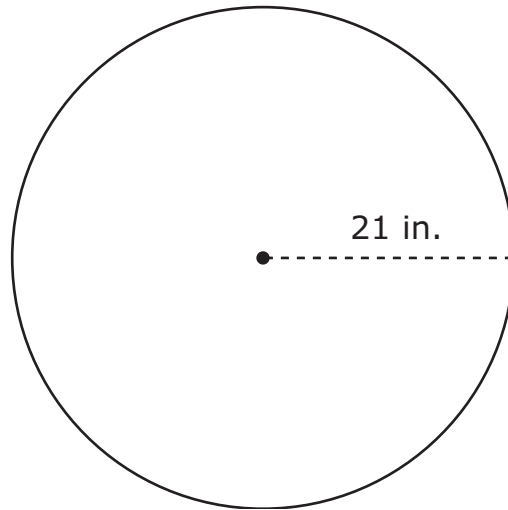

$$A = \pi r^2$$

Area of a circle = $\pi \cdot \text{radius} \cdot \text{radius}$

Which value is closest to the area of the mirror?

- F** 132 in.²
- G** 1,385 in.²
- H** 4,348 in.²

25 Look at the graph below. It shows the number of items sold at a school store last week.

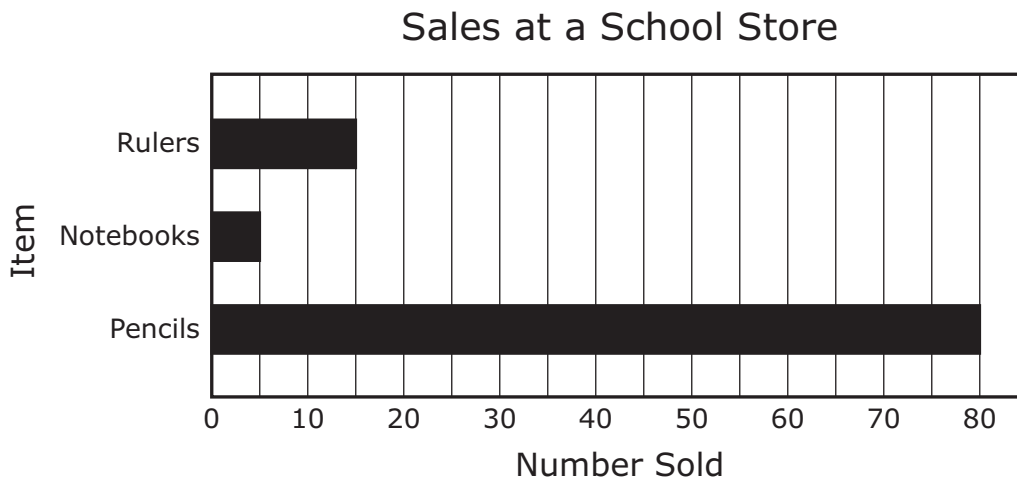

Which statement is supported by the graph?

- A** The number of pencils sold was $\frac{3}{4}$ the total number of items sold.
- B** The total number of notebooks and pencils sold was 20.
- C** The total number of rulers, notebooks, and pencils sold was 100.

26 What is the value of the expression below?

$$4^2 \div 2 + 4$$

F 12

G 8

H 36

27 Which of these represents a pair of similar polygons?

A

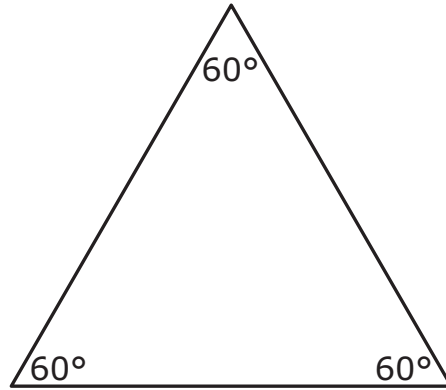
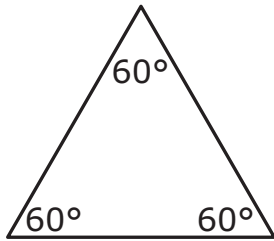

B

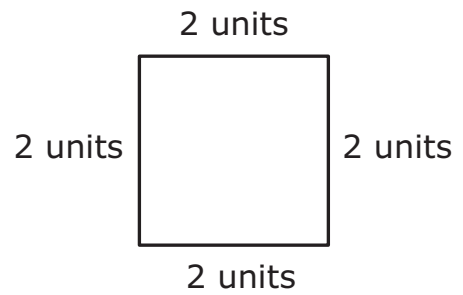
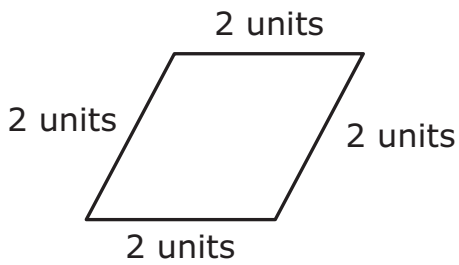

C

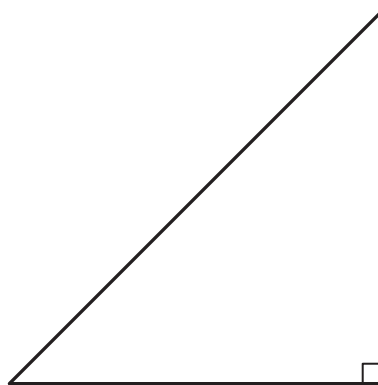
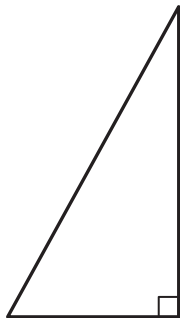

28 Martin is playing a game using the two spinners below.

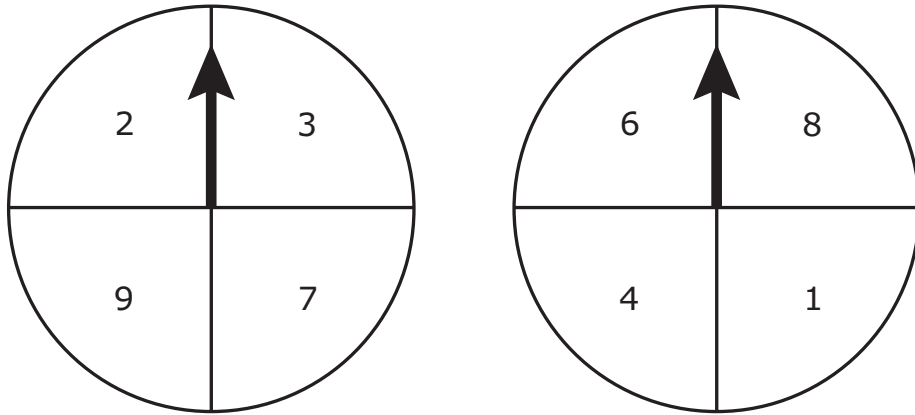

He spins each spinner once and adds the numbers the arrows land on. Which list shows only the possible outcomes of two numbers that will give Martin a sum of 10?

- F** 9 and 1, 2 and 8, 7 and 4
- G** 9 and 1, 2 and 8
- H** 9 and 1, 2 and 8, 7 and 3, 4 and 6

29 Look at the table below. It shows the prices for washing vehicles at a car wash.

Car Wash

| Car | \$12 |
|-----|------|
| Van | \$15 |

What is one way to find the price in dollars of washing 20 cars and 16 vans?

- A** Add 20 and 12, add 16 and 15, and then multiply the sums
- B** Multiply 20 by 12, multiply 16 by 15, and then add the products
- C** Multiply 20 by 16, multiply 12 by 15, and then add the products

30 The model below represents the equation $x + 1 = 8$.

$$\textcircled{x} \boxed{1} = \begin{array}{cccc} \boxed{1} & \boxed{1} & \boxed{1} & \boxed{1} \\ \boxed{1} & \boxed{1} & \boxed{1} & \boxed{1} \end{array}$$

What value of x makes this equation true?

- F** $x = 7$
- G** $x = 9$
- H** $x = -7$

31 Mr. Harris wants to put bricks around the circumference of a garden shaped like a circle. The diameter of the garden is 7.8 meters.

$$C = \pi d$$

Circumference of a circle = $\pi \cdot$ diameter

Which value is closest to the circumference of the garden?

- A** 64 meters
- B** 12 meters
- C** 24 meters

32 A triangle has an area of 36 square centimeters and a height of 4 centimeters. Which equation can be used to find b , the length of the base of the triangle in centimeters?

F $36 = (b)(4)$

G $36 = \frac{(b)(4)}{2}$

H $36 = \frac{(b \cdot 4)^2}{2}$

33 Look at the table below. It shows the names of the student council members in each grade at a middle school.

Student Council

| Rachel | Ken | Farah |
|--------|------|-------|
| | Cari | Omar |

Which diagram shows all the possible outcomes of one student council member from each grade who can attend a meeting?

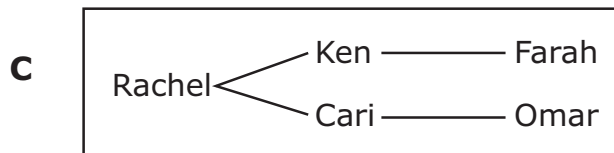
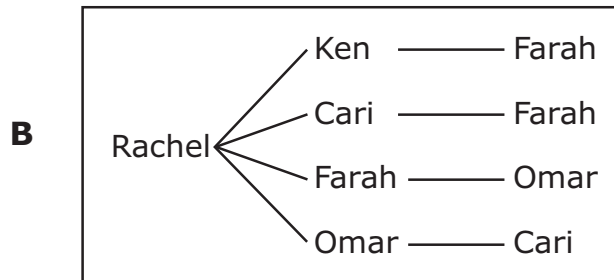
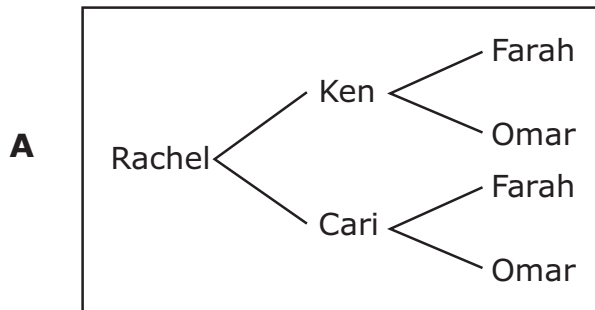

- 34** Look at the figure below. It is a scale drawing of the floor of a library. Find the ruler marked in inches on the reference materials. Measure the side lengths of this figure to the nearest inch.

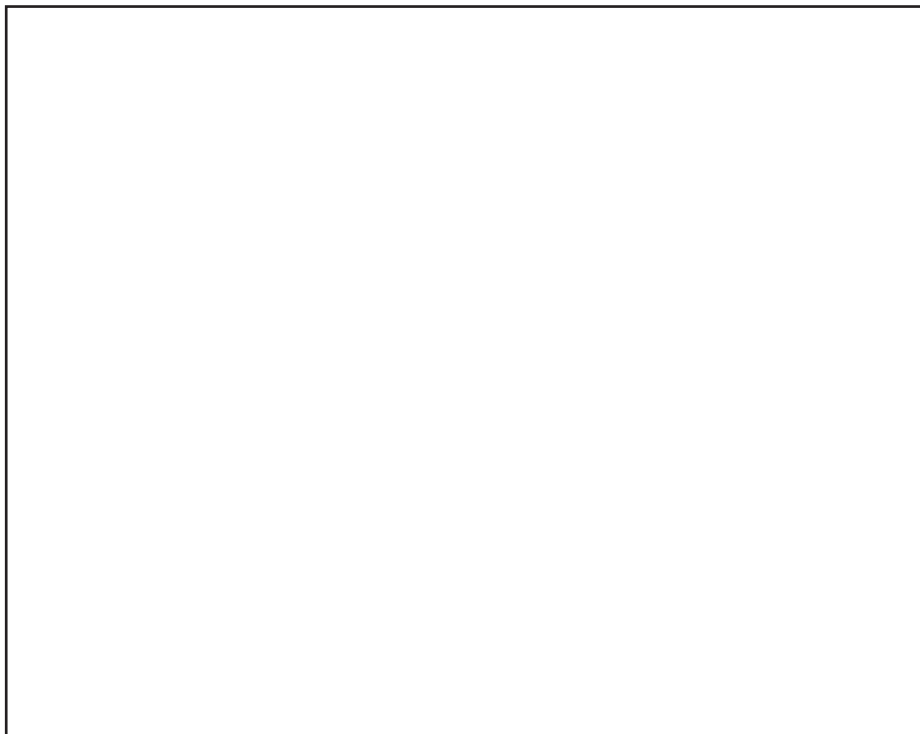

In the scale drawing, 1 inch represents 4 feet. Which of these is closest to the perimeter of the library's actual floor in feet?

F 36 feet

G 72 feet

H 18 feet

- 35** Nick can run 600 yards in 2 minutes. At this rate, how many yards can he run in 12 minutes?
- A** 100 yards
 - B** 6,000 yards
 - C** 3,600 yards

36 All the items at a store were on sale for 60% of the original price. Which fraction is equivalent to 60%?

F $\frac{3}{50}$

G $\frac{3}{5}$

H $\frac{1}{6}$

- 37** A jar in the shape of a cylinder has a radius of 3 inches and a height of 10 inches.

$$V = \pi r^2 h$$

Volume of a cylinder = $\pi \cdot \text{radius} \cdot \text{radius} \cdot \text{height}$

Which of these is closest to the volume of the jar?

- A** 1,130 cubic inches
- B** 280 cubic inches
- C** 188 cubic inches

38 A school band needs money for a trip.

- They have \$600.
- This is 50% of the total amount of money they need.

What is the total amount of money the band needs for the trip?

- F** \$300
- G** \$900
- H** \$1,200

39 Josh rides the school bus each day. He rides for 0.75 hour in the morning and 0.6 hour in the afternoon. How many hours does he spend riding the school bus in 5 days?

- A** 6.75 hours
- B** 1.35 hours
- C** 6.35 hours

40 Which grid shows only a translation of $\triangle MNP$ to form $\triangle M'N'P'$?

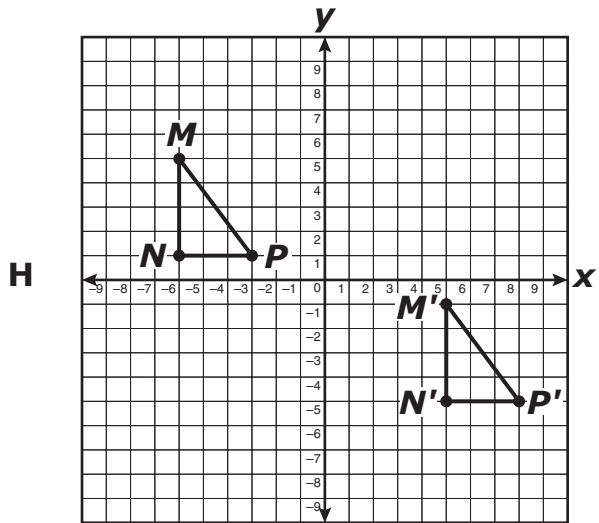
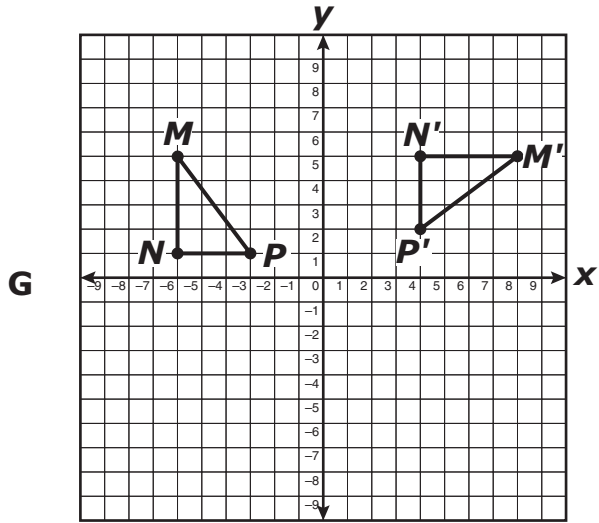
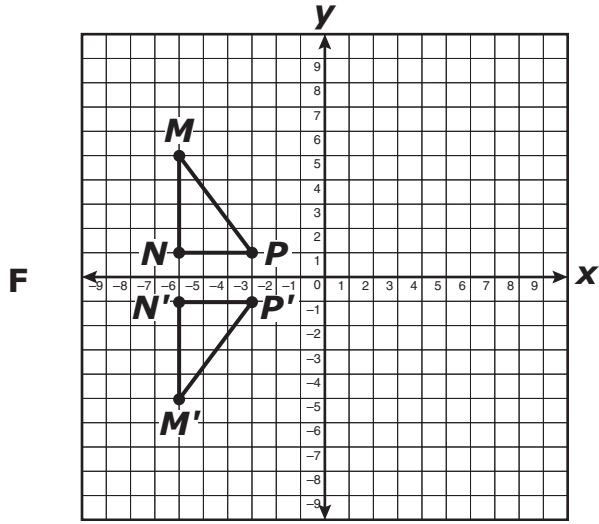

41 Felix walks dogs to earn money.

- Yesterday he earned \$60.
- He earned \$5 per dog.
- He walked n dogs.

Which equation represents this situation?

A $\frac{n}{5} = 60$

B $5n = 60$

C $n - 5 = 60$

42 The monthly rent for an apartment at 3 different buildings was \$525, \$670, and \$600. Which measure of the data can be used to describe the difference between the most expensive and least expensive monthly rent?

F Mean

G Median

H Range

43 Look at the cube below.

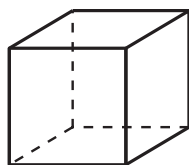

Which figure has more vertices than a cube?

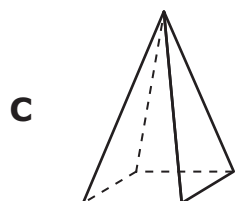
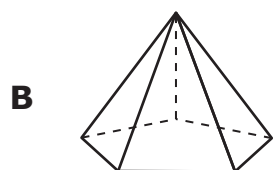
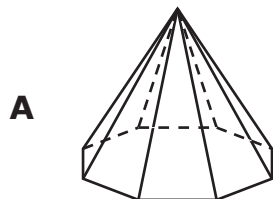

BE SURE YOU HAVE RECORDED ALL OF YOUR ANSWERS ON THE ANSWER DOCUMENT.



**STAAR MODIFIED
GRADE 7
Mathematics
April 2014**